

FEATURES

The plastic package carries Underwriters Laboratory Flammability Classification 94V-0
 For surface mounted applications
 Super fast switching for high efficiency
 Low reverse leakage
 Built-in strain relief, ideal for automated placement
 High forward surge current capability
 High temperature soldering guaranteed:
 260°C/10 seconds at terminals

MECHANICAL DATA

Case: JEDEC SMBF molded plastic body
Terminals: Solder plated, solderable per MIL-STD-750, Method 2026
Polarity: Color band denotes cathode end
Mounting Position: Any

SMBF

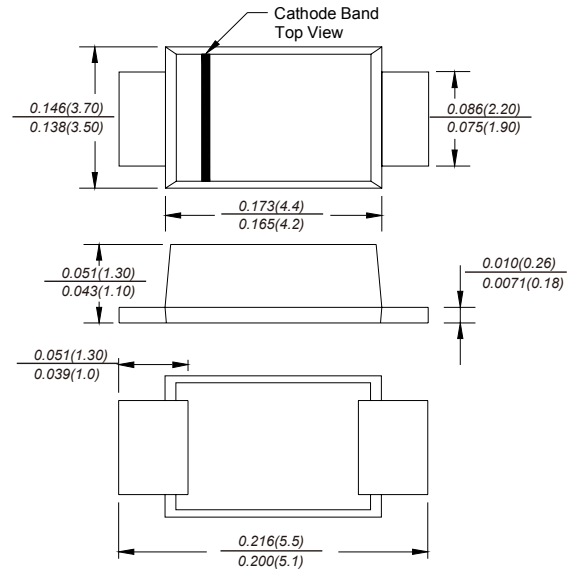

Dimensions in inches and (millimeters)

MAXIMUM RATINGS AND ELECTRICAL CHARACTERISTICS

Ratings at 25°C ambient temperature unless otherwise specified.
 Single phase half-wave 60Hz, resistive or inductive load, for capacitive load current derate by 20%.

	SYMBOLS	ES5ABF	ES5BBF	ES5CBF	ES5DBF	ES5EBF	ES5GBF	ES5JBF	UNITS
Maximum repetitive peak reverse voltage	V_{RRM}	50	100	150	200	300	400	600	V
Maximum RMS voltage	V_{RMS}	35	70	105	140	210	280	420	V
Maximum DC blocking voltage	V_{DC}	50	100	150	200	300	400	600	V
Maximum average forward rectified current at $T_L=75^\circ\text{C}$	$I_{(AV)}$	5.0							A
Peak forward surge current 8.3ms single half sine-wave superimposed on rated load	I_{FSM}	150.0							A
Maximum instantaneous forward voltage at 5.0A	V_F	0.95			1.25		1.7		V
Maximum DC reverse current $T_A=25^\circ\text{C}$ at rated DC blocking voltage $T_A=100^\circ\text{C}$	I_R	5.0 100.0							μA
Maximum reverse recovery time	t_{rr}	35							ns
Typical junction capacitance	C_J	58.0							pF
Typical thermal resistance	$R_{\theta JA}$	55.0							$^\circ\text{C}/\text{W}$
Operating junction and storage temperature range	T_J, T_{STG}	-55 to +150							$^\circ\text{C}$

Note: 1. Reverse recovery condition $I_F=0.5\text{A}, I_R=1.0\text{A}, I_{rr}=0.25\text{A}$
 2. Measured at 1MHz and applied reverse voltage of 4.0V D.C.



AVERAGE FORWARD RECTIFIED CURRENT, AMPERES

FIG. 1- FORWARD CURRENT DERATING CURVE

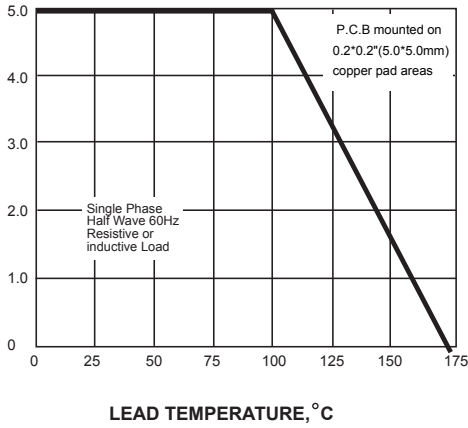

PEAK FORWARD SURGE CURRENT, AMPERES

FIG. 2-MAXIMUM NON-REPETITIVE PEAK FORWARD SURGE CURRENT

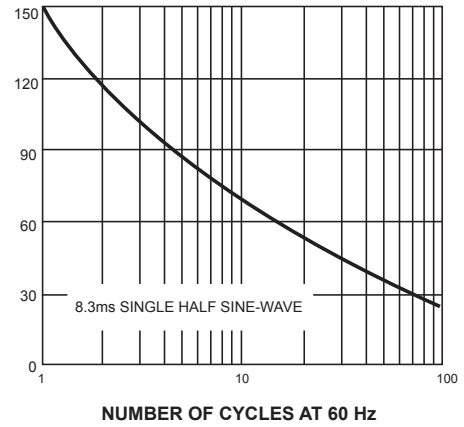

INSTANTANEOUS FORWARD CURRENT, AMPERES

FIG. 3-TYPICAL INSTANTANEOUS FORWARD CHARACTERISTICS

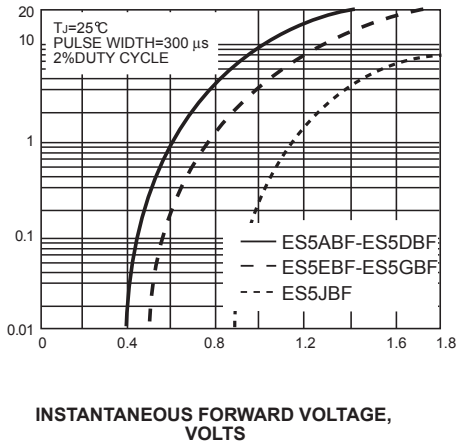

INSTANTANEOUS REVERSE CURRENT, MICROAMPERES

FIG. 4-TYPICAL REVERSE CHARACTERISTICS

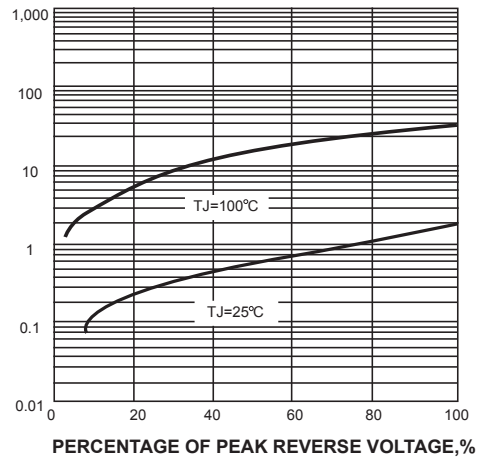

JUNCTION CAPACITANCE, pF

FIG. 5-TYPICAL JUNCTION CAPACITANCE

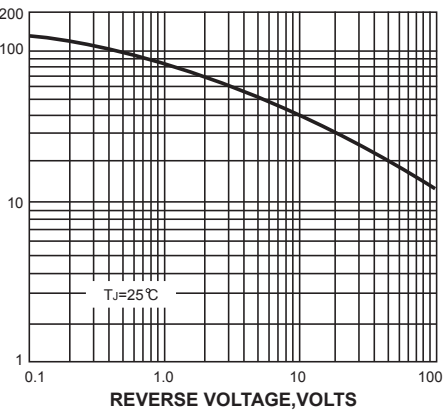

TRANSIENT THERMAL IMPEDANCE, °C/W

FIG. 6-TYPICAL TRANSIENT THERMAL IMPEDANCE

