

FEATURES

The plastic package carries Underwriters Laboratory Flammability Classification 94V-0
 For surface mounted applications
 Ultra fast switching for high efficiency
 Low reverse leakage
 Built-in strain relief, ideal for automated placement
 High forward surge current capability
 High temperature soldering guaranteed
 260°C/10 seconds at terminals
 Glass passivated chip junction

SMAF

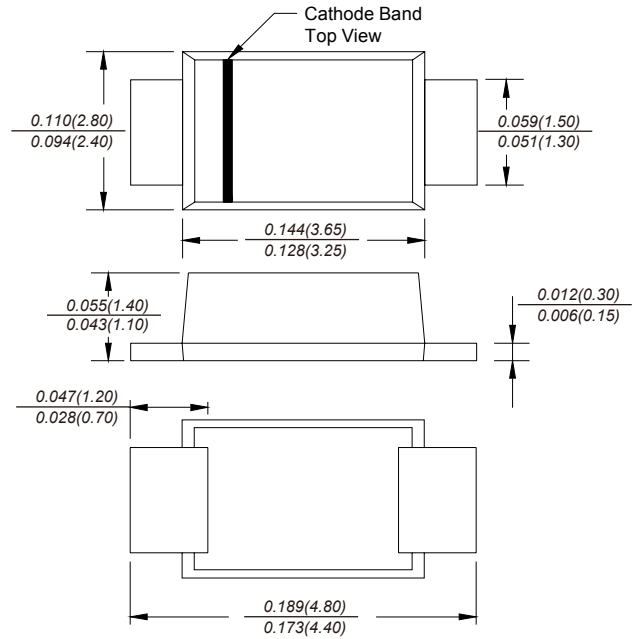

Dimensions in inches and (millimeters)

MECHANICAL DATA

Case: SMAF molded plastic body over passivated chip

Terminals: Solder plated, solderable per MIL-STD-750, Method 2026

Polarity: Color band denotes cathode end

Mounting Position: Any

Weight: 0.0014 ounce, 0.038grams

MAXIMUM RATINGS AND ELECTRICAL CHARACTERISTICS

Ratings at 25°C ambient temperature unless otherwise specified.

Single phase half-wave 60Hz, resistive or inductive load, for capacitive load current derate by 20%.

	SYMBOLS	ES1AF	ES1BF	ES1CF	ES1DF	ES1EF	ES1GF	ES1JF	UNITS
Maximum repetitive peak reverse voltage	V_{RRM}	50	100	150	200	300	400	600	V
Maximum RMS voltage	V_{RMS}	35	70	105	140	210	280	420	V
Maximum DC blocking voltage	V_{DC}	50	100	150	200	300	400	600	V
Maximum average forward rectified current at $T_L=110^\circ\text{C}$	$I_{(AV)}$	1.0							A
Peak forward surge current 8.3ms single half sine-wave superimposed on rated load	I_{FSM}	30.0							A
Maximum instantaneous forward voltage at 1.0A	V_F	0.95			1.25		1.7		V
Maximum DC reverse current at rated DC blocking voltage	I_R				5.0				μA
					50.0				
Maximum reverse recovery time	t_{rr}	35							ns
Typical junction capacitance	C_J	15.0							pF
Typical thermal resistance	$R_{\theta JA}$	88.0							$^\circ\text{C/W}$
Operating junction and storage temperature range	T_J, T_{STG}	-55 to +150							$^\circ\text{C}$

Note: 1. Reverse recovery condition $I_F=0.5\text{A}, I_R=1.0\text{A}, I_{rr}=0.25\text{A}$

2. Measured at 1MHz and applied reverse voltage of 4.0V D.C.



AVERAGE FORWARD RECTIFIED CURRENT, AMPERES

FIG. 1- FORWARD CURRENT DERATING CURVE

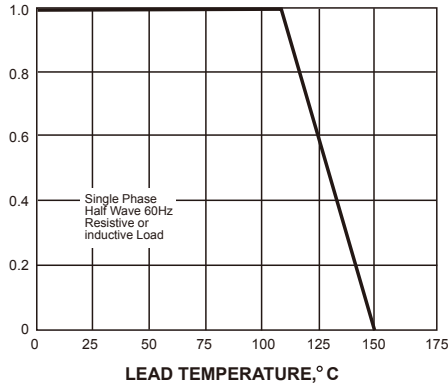

PEAK FORWARD SURGE CURRENT, AMPERES

FIG. 2-MAXIMUM NON-REPETITIVE PEAK FORWARD SURGE CURRENT

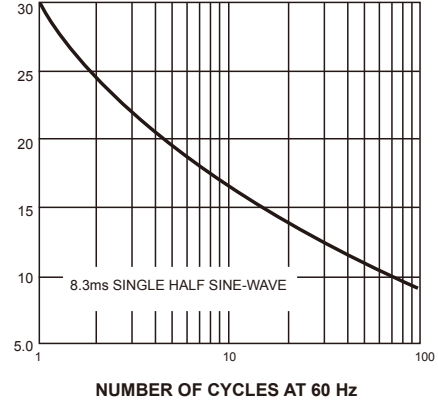

INSTANTANEOUS FORWARD CURRENT, AMPERES

FIG. 3-TYPICAL INSTANTANEOUS FORWARD CHARACTERISTICS

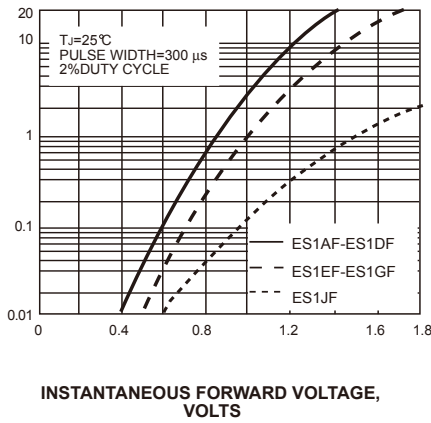

INSTANTANEOUS REVERSE CURRENT, MICROAMPERES

FIG. 4-TYPICAL REVERSE CHARACTERISTICS

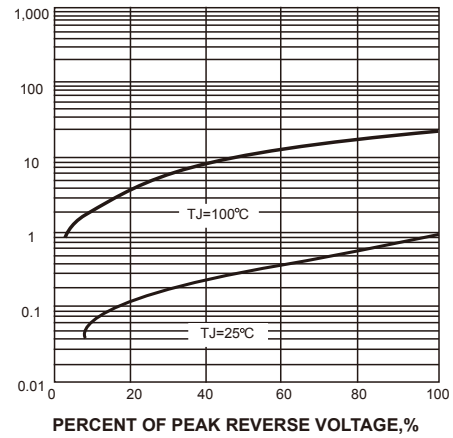

JUNCTION CAPACITANCE, pF

FIG. 5-TYPICAL JUNCTION CAPACITANCE

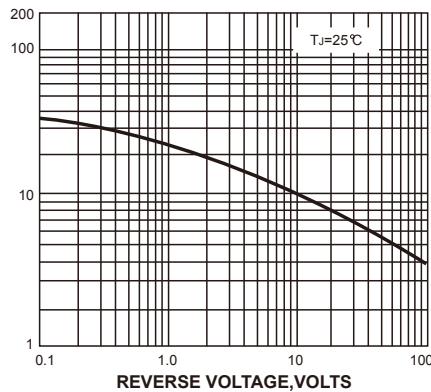

TRANSIENT THERMAL IMPEDANCE, °C/W

FIG. 6-TYPICAL TRANSIENT THERMAL IMPEDANCE

