



# 5A05 THRU 5A10

5.0 AMPS. General Purpose Silicon Rectifiers

## FEATURES

The plastic package carries Underwriters Laboratory  
 Flammability Classification 94V-0  
 Fast switching for high efficiency  
 Low reverse leakage  
 High forward surge current capability  
 High temperature soldering guaranteed:  
 260°C/10 seconds, 0.375" (9.5mm) lead length,  
 5 lbs. (2.3kg) tension

## MECHANICAL DATA

**Case:** JEDEC DO-201AD molded plastic body  
**Terminals:** Plated axial leads, solderable per MIL-STD-750,  
 Method 2026  
**Polarity:** Color band denotes cathode end  
**Mounting Position:** Any  
**Weight:** 0.04 ounce, 1.10 grams

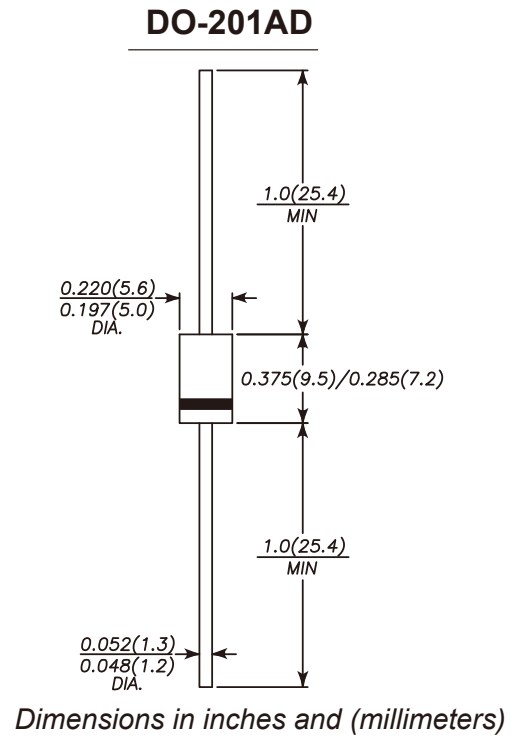

## MAXIMUM RATINGS AND ELECTRICAL CHARACTERISTICS

Ratings at 25°C ambient temperature unless otherwise specified.  
 Single phase half-wave 60Hz, resistive or inductive load, for capacitive load current derate by 20%.

	SYMBOLS	5A05	5A1	5A2	5A4	5A6	5A8	5A10	UNITS
Maximum repetitive peak reverse voltage	$V_{RRM}$	50	100	200	400	600	800	1000	V
Maximum RMS voltage	$V_{RMS}$	35	70	140	280	420	560	700	V
Maximum DC blocking voltage	$V_{DC}$	50	100	200	400	600	800	1000	V
Maximum average forward rectified current 0.375" (9.5mm) lead length at $T_A=75^\circ\text{C}$	$I_{(AV)}$	5.0							A
Peak forward surge current 8.3ms single half sine-wave superimposed on rated load (JEDEC Method)	$I_{FSM}$	240							A
Maximum instantaneous forward voltage at 6.0A	$V_F$	1.1							V
Maximum DC reverse current $T_A=25^\circ\text{C}$ at rated DC blocking voltage $T_A=100^\circ\text{C}$	$I_R$	10.0 400							$\mu\text{A}$
Typical junction capacitance (NOTE 1)	$C_J$	150							pF
Typical thermal resistance (NOTE 2)	$R_{\theta JA}$	10.0							$^\circ\text{C/W}$
Operating junction and storage temperature range	$T_J, T_{STG}$	-55 to +150							$^\circ\text{C}$

**Note:** 1. Measured at 1MHz and applied reverse voltage of 4.0V D.C.  
 2. Thermal resistance from junction to ambient at 0.375" (9.5mm) lead length, P.C.B. mounted





# 5A05 THRU 5A10

5.0 AMPS. General Purpose Silicon Rectifiers

AVERAGE FORWARD RECTIFIED CURRENT,  
AMPERES

FIG. 1- FORWARD CURRENT DERATING CURVE

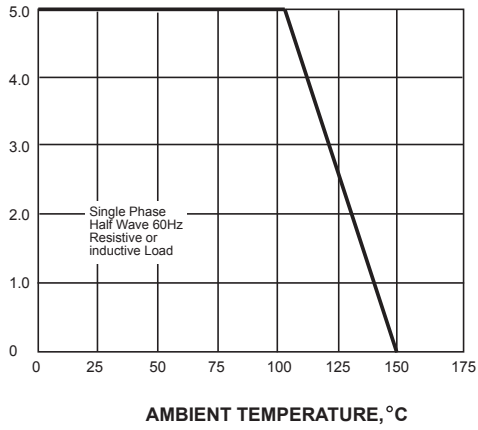

PEAK FORWARD SURGE CURRENT,  
AMPERES

FIG. 2-MAXIMUM NON-REPETITIVE PEAK FORWARD SURGE CURRENT

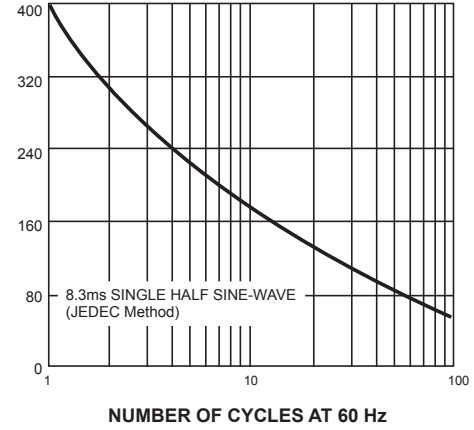

INSTANTANEOUS FORWARD CURRENT, AMPERES

FIG. 3-TYPICAL INSTANTANEOUS FORWARD CHARACTERISTICS

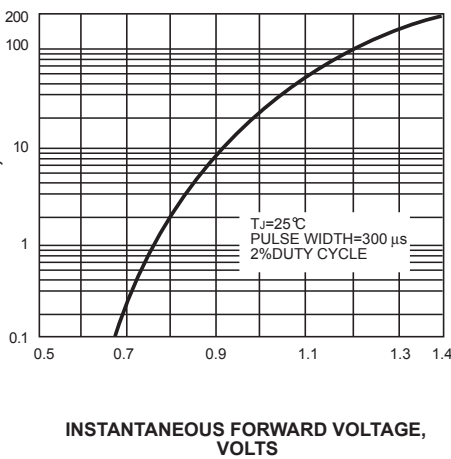

INSTANTANEOUS REVERSE CURRENT,  
MICROAMPERES

FIG. 4-TYPICAL REVERSE CHARACTERISTICS

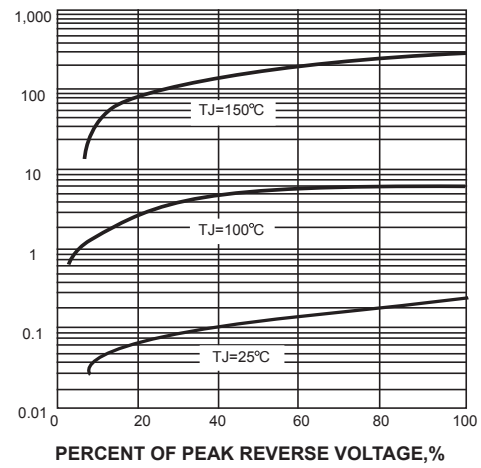

JUNCTION CAPACITANCE, pF

FIG. 5-TYPICAL JUNCTION CAPACITANCE

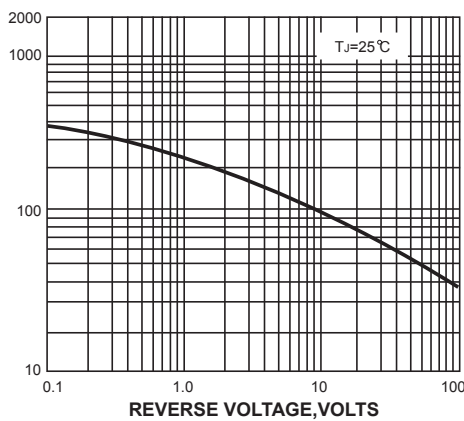

TRANSIENT THERMAL IMPEDANCE,  
°C/W

FIG. 6-TYPICAL TRANSIENT THERMAL IMPEDANCE

